

PRECAST SQUARE SUMP 900 mm Square

WILKINSON HEAVY PRECAST LIMITED

DUNDAS, ONTARIO

905-628-5611

www.wilkinsonheavyprecast.com

CONSTRUCTION DETAILS

Concrete: 35 MPa at 28 Days, 5 to 8% Air Entrainment.

Reinforcing: 4 x 4 6/6 ww mesh in walls and floor.
10 M Bars at 150 mm each way in roof slab.
Minimum cover over reinforcing steel - 25 mm.

DIMENSION CHART

Description	1.2 M	1.5 M	1.8 M
A. Height (mm)	1220	1525	1830
B. Inlet Invert to Bottom	1015	1320	1625
C. Outlet Invert to Bottom	965	1270	1575
• Weight (Kg)	1175	1425	1680

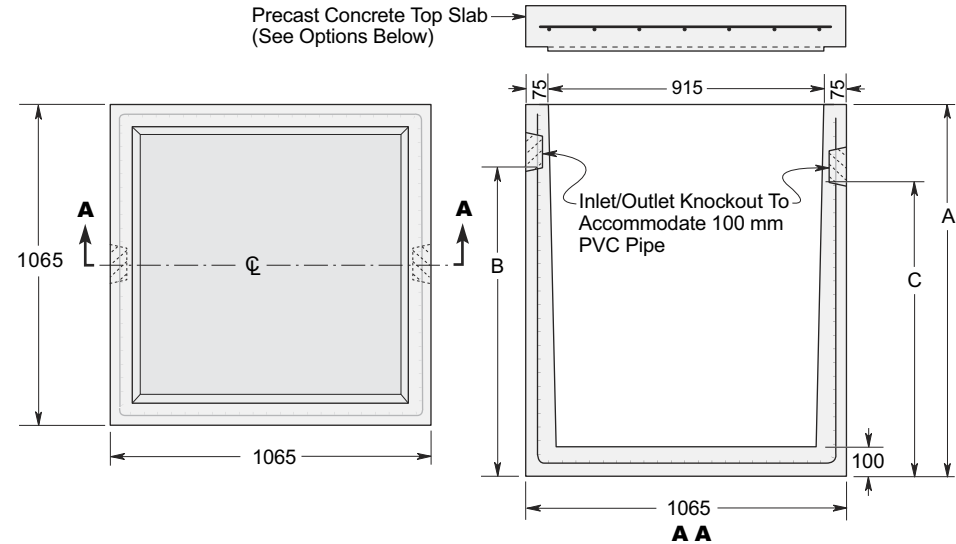

OPTIONAL COVERS FOR SQUARE SUMPS

PRECAST CONCRETE TOP SLAB AND CAST IRON COVER

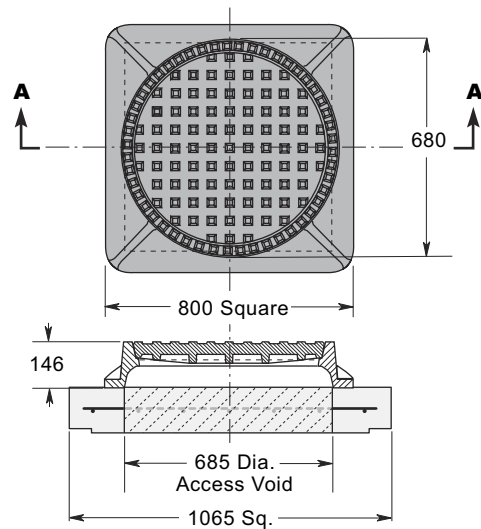

CAST IRON FRAME & GASKETED BOLT-DOWN COVER
Cast into Precast Concrete Top Slab

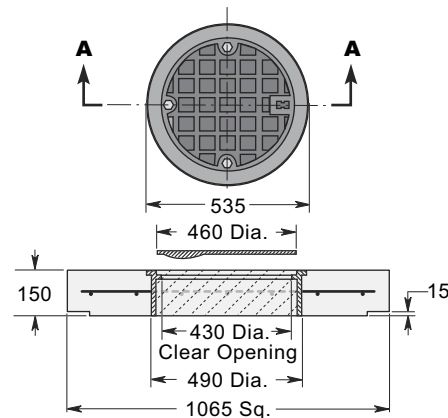

ALUMINUM LOCKABLE & GASKETED FLUSH TYPE HATCH
Supplied Loose

- Standard Hatch rated for 300 Lbs. per sq. ft.
- Heavier load rated hatches available upon request.

